

Skyline 3.0Nm & 6.0Nm | 35mm

The motorized Skyline roller shade system offers a range of four Automate motors with one tube diameter to suit a variety of applications. Featuring ARC (Automate Radio Communication), the 35mm Skyline Automate system provides an intelligent, Li-ion battery or a DC powered solution.

**AESTHETIC FEATURES**

- Slim motor head for minimal light gap
- Motor cap to color match with brackets

**ASSEMBLY / PRODUCTION FEATURES**

- Greater flexibility with installation with spring loaded pin end
- Crown, drive and adaptors available to suit variety of applications

**FUNCTIONAL BENEFITS**

- 5V Micro USB Charging
- Leveling control
- Simple limit setting and adjustment
- Favorite position
- 3 operational speed settings
- 2-way RF communication
- ARC protocol for simple programming

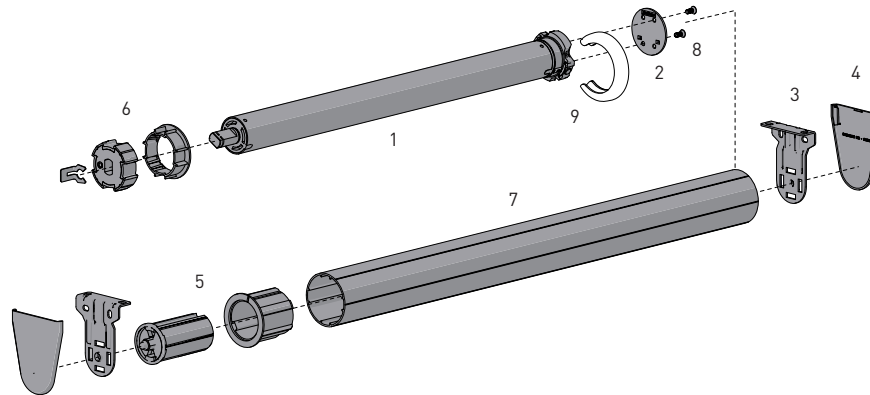

**SYSTEM INDEX**

1	Automate Motor   35mm MT01-1335-069001 - Li-ion 3.0 5V MTDCBRF35-3 - Li-ion 3.0 12V MTDCRF35-3 - DCRF 3.0 12V MTACRF35-6 - ACRF 6 12V MTACQRF35-6 - ACRF Q6 12V
2	Motor Adaptor MTAD-252835-SL
3	Brackets SLB###x SLNB###x
4	Bracket Covers SLBC###x SLNBC###x
5	Pin End & Adaptor SLPEHD53xx + RA2xx
6	Crown & Drive Kit MTCRDR-35-2 - Kit for 2" Tube
7	Aluminum Tube RTEAST## - 2" Tube
8	Screws for Adaptor SLAMSCREW
9	Motor Cap MTCAP-35-BK - Black MTCAP-35-W - White MTCAP-35-AB - Antique Bronze MTCAP-35-SN - Satin Nickel

# - Size  
xxx= Color

**COLOR RANGE**

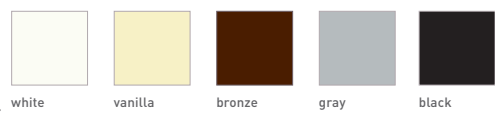

**CONTROL OPTIONS**

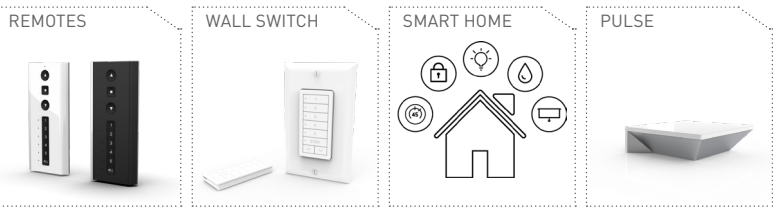

**CHARGERS**



**OPTIONS**

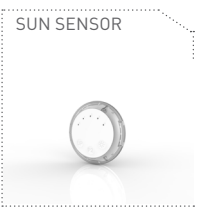

**SYSTEM UPGRADES**

**SPECIFICATIONS**

**DEDUCTION CHART**

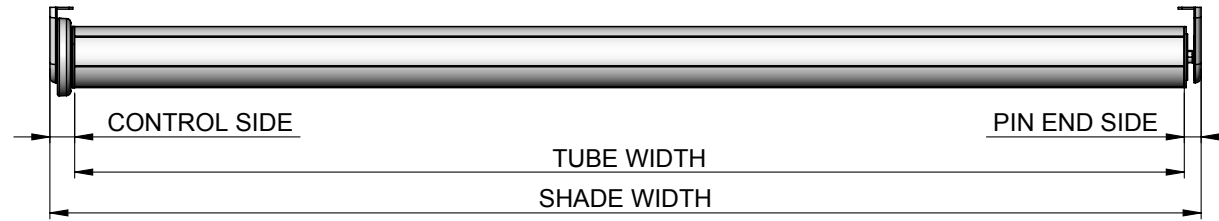

MINIMUM SHADE WIDTH	
MOTOR	LENGTH
MT01-1335-069001	3.18' [0.970m]
MTDCBRF35-3	3.18' [0.970m]
MTDCRF35-3	1.87' [0.570m]
MTACRF35-6	2.26' [0.690m]
MTACQRF35-6	2.13' [0.650m]

MOTOR	TUBE	BRACKETS	LIGHT GAP		
			CONTROL END	PIN END	OVERALL
MT01-1335-069001 MTDCBRF35-3 MTDCRF35-3 MTACRF35-6 MTACQRF35-6	2"	With Covers	0.83" [21mm]	0.59" [15mm]	1.42" [36mm]
		No Covers	0.75" [19mm]	0.55" [14mm]	1.30" [33mm]

**MAX ROLL**

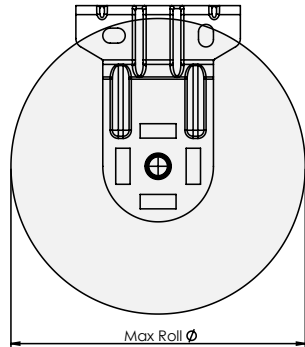

BRACKET	MAX ROLL SIZE
SLNBxx650xx	2-3/8" [59mm]
SLxx660xx	3" [76mm]
SLxx680xx	4" [102mm]
SLxx690xx	5" [128mm]

**TUBE SPECS.**

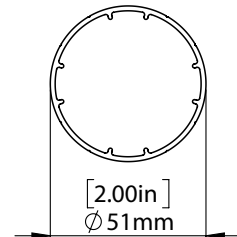

2" Tube  
Code: RTEA5T12 (with tape)  
RTEA5U12  
RTEA5T16 (with tape)  
RTEA5U16

Length 12', 16'  
[3.66m, 4.88m]

MAX LIFTING CAPACITY		MAX DROP*
MOTORS	2" TUBE	
3.0Nm	26.4lbs [12.0kg]	13.1' [4m]
6.0Nm	52.9lbs [24.0kg]	

\* Recommended Max Drop. Exceeding this value may cause fabric tracking issues

**SYSTEM CAPACITY**

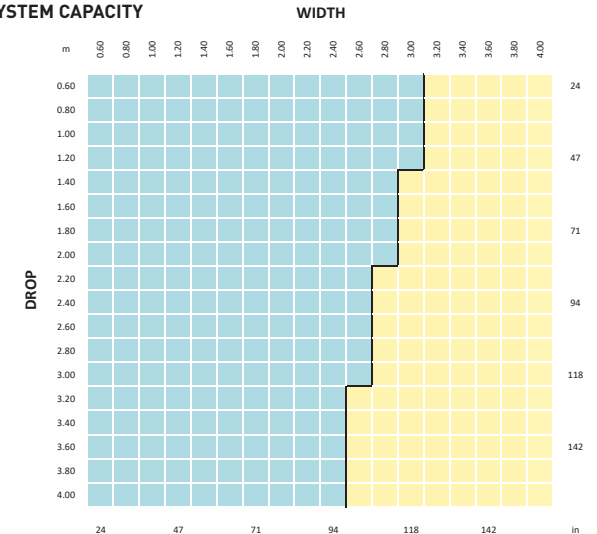

TUBE	PARAMETERS
2" TUBE	FABRIC DENSITY: 420gsm
LINKED SYSTEM	FABRIC THICKNESS: 0.6mm
	WEIGHT BAR: D30 Medium Bottom Rail
	CONTROL: 3.0Nm & 6.0Nm MOTORS