

Mechanical Limit Motors Operator Wiring Considerations

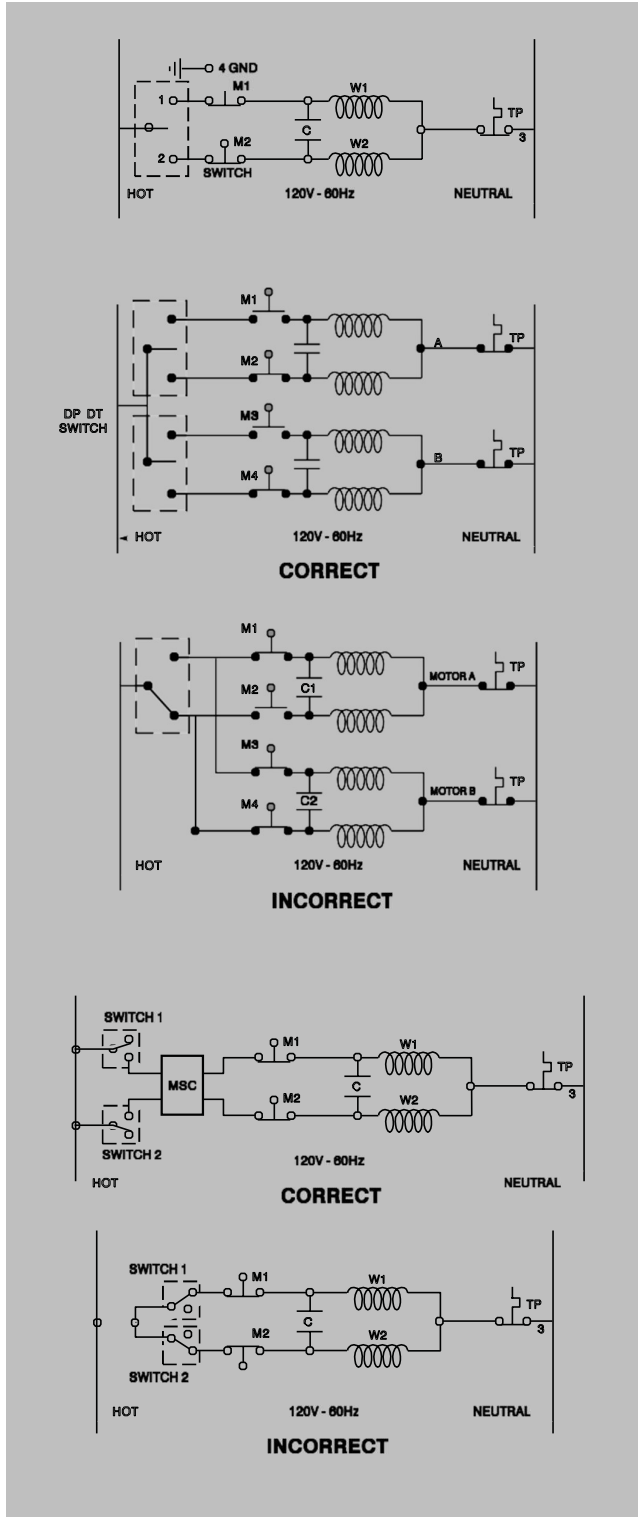

Because of the type of motor (Asynchronous with built-in capacitor) and the built-in limit switches, it is important to follow two important recommendations to assure proper operation of the motorized systems - Automate Operators are not universal motors.

SYMBOLS			
M1	Microswitch	W2	Motor Winding
M2	Microswitch	TP	Thermal Protector
C	Capacitor	GND	Ground
W1	Motor Wiring		

The operator is connected to a 120V-60HZ power source through a single pole (or double pole), double throw, center off switch.

1. Do Not Wire Automate Operators in Parallel (Does not apply to ARC motors). Parallel Wiring Means: Several Operators are Wired to Only One Electrical Contact Per Direction of Rotation.

There will be constant feedback from one motor to another, so stopping points will not be stable and there is a risk of motor burn out.

Correct:

Correct wiring solution is to use a double pole, double throw, center off switch which would isolate both motors.

Incorrect:

Motor A stops at its limit in direction 2 before Motor B. Current in Motor B feeds back to motor A through capacitor C2 and microswitches M3 and M1. Both operators keep rotating in opposite directions at reduced power.

2. Do Not Control One Automate Operator from Several Locations Without Using Proper Controller.

Correct:

Possible problem: When switch (1) is turned on, the motor will begin running in direction 1. As it reaches its limit, the microswitch M1 will open. If, at the same moment in time switch (2) is turned on, the motor will operate in the opposite direction. This is why we recommend the use of momentary switches with the Multi-Switch Command (MSC).

Incorrect:

The microswitch M1 closes, short-circuiting the capacitor which is loaded at its maximum voltage (180V). As a result, the microswitch M1 is damaged.

Solution: Use relays to build priorities between controls sending opposite signals. Do not use a standard "light" switch as a motor control.

NOTE: Automate Control Systems are designed to comply with these two basic criteria and assure reliable operation of motorized systems. Non-compliance to these two basic principles voids the Automate warranty.